



# OCMM

**MANUFACTURING CATALOG**

**20  
25**



PHONE: (610) 557-0303 | WEBSITE: [OCM-INC.COM/OCMMANUFACTURING](http://OCM-INC.COM/OCMMANUFACTURING)  
250 HANSEN ACCESS ROAD, KING OF PRUSSIA PENNSYLVANIA, 19406





# About OCMM

OCM Manufacturing is a premier provider of high-quality accessories and solutions for the concrete construction industry. With a rich history of innovation and expertise, has been a trusted partner for contractors, builders, and construction professionals for many years.

Our extensive product line includes a wide range of concrete forming accessories and reinforcement products designed to enhance efficiency, durability, and performance on job sites of all sizes. From forming hardware and tilt-up braces to snap ties and bar supports, OCMM offers solutions that meet the rigorous demands of concrete construction projects.

At OCMM, we are committed to excellence in both product quality and customer service. Our team of Knowledgeable professionals works closely with clients to understand their specific needs and deliver tailored solutions that optimize productivity and ensure Superior results.

With a focus on innovation and continuous improvement, OCMM remains at the forefront of the industry, providing reliable products and exceptional service that contribute to the success of construction projects nationwide.





# Table Of Contents

About OCMM	Page 01
Table Of Contents	Page 02
Ties	Page 03 - 04
Inserts	Page 05
Coil Rod & Screed	Page 06
Slab Bolster Upper & Form Savers	Page 07
Slab Bolster	Page 08
Continuous High Chair Upper	Page 09
Continuous High Chair	Page 10
Individual High Chair	Page 11
Beam Bolster & Beam Bolster Upper	Page 12
Steel-Ply Forms	Page 13
Bridge Hangers and Deck Bolts	Page 14



# Snap Ties

We manufacture snap ties ranging from 6" to 60" along with custom sizes with either cones or washers and the option of long end or short end with hex ends. *Waterseal available as well.*



End	Wall Size	Type	Safe Working Load
Long & Short End Hex	6" - 60"	Cone	2,250 lbs.
Long & Short End Hex	6" - 60"	Washer	2,250 lbs.
Long & Short End Hex	6" - 48"	Cone HD	3,250 lbs.
Long & Short End Hex	6" - 48"	Washer HD	3,250 lbs.

## Snap Tie PN Breakdown

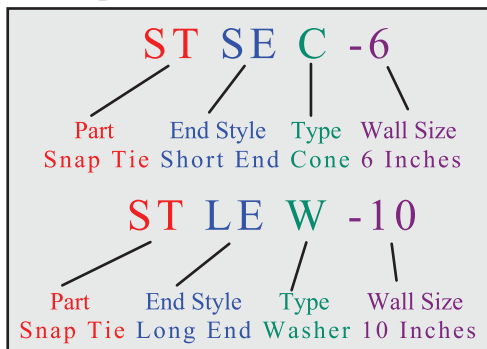

# Coil Ties

We manufacture Coil Ties with 2 or 4 struts, ranging in sizes from 4" to 42" along with Cone fast Coil Ties and waterseal.

## Coil Tie PN Breakdown

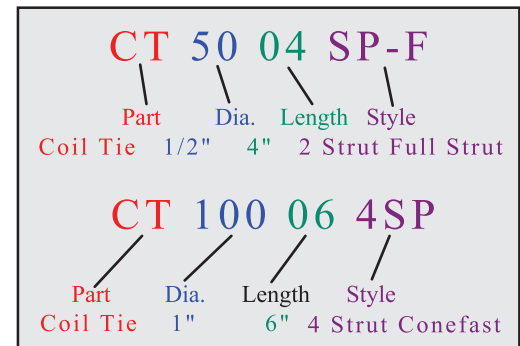

Dia.	Length	Type	Safe Work Load
1/2"	4" - 42"	2 Strut	4,500 lbs.
3/4"	6" - 24"	2 Strut	6,750 lbs.
1"	6" - 24"	2 Strut	13,500 lbs.
1"	6" - 12"	4 Strut	18,000 lbs.
1 1/4"	6" - 12"	4 Strut	27,000 lbs.
3/4"	6" - 12"	4 Strut HD	18,000 lbs.
1"	6" - 12"	4 Strut HD	27,000 lbs.

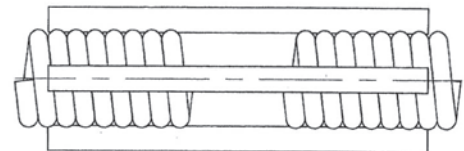

# Combo Ties

Combo Ties are manufactured with either a Standard Loop Tie or Snap Tie on one end and a 1/2" Coil Tie on the other end. They can be used in Steel Frame Form or Snap Tie one sided or blind side forming applications. Standard sizes of 4", 6", and 8" are in stock, but can be used with field cut lengths of Coil Rod to form different size walls.

Type	Wall size	Safe Work Load	Part Number
HD Loop Tie	4" - 8"	3,000 lbs.	COMBO-50C/HDL-4 COMBO-50C/HDL-6 COMBO-50C/HDL-8
Snap Tie	4" - 8"	2,250 lbs.	COMBO-50C/LEST
Spandrel Tie	≤ 144"	250 lbs.	Custom Based On Config





# Loop Ties

We manufacture Loop Ties ranging in size from 6" to 60" along with coned, water sealing, and heavy duty Loop Ties.

Loop Tie PN Breakdown

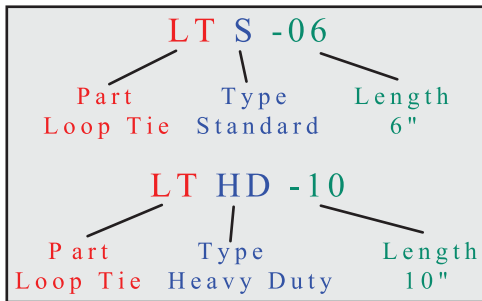

Type	Wall Size	Safe Working Load
HD Loop Tie	6" - 60"	3,000 lbs.
HD Waterseal	8" - 16"	3,000 lbs.

# Flat Ties

We manufacture Flat Ties in sizes ranging from 4" to 84" along with heavy duty Flat Ties.

Flat Tie PN Breakdown

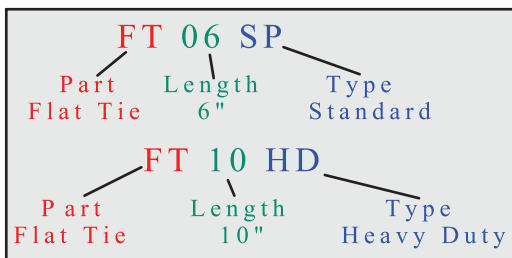

Type	Wall Size	Safe Working Load
Flat Tie	4" - 84"	3,000 lbs.
HD Flat Tie	6" - 18"	3,500 lbs.

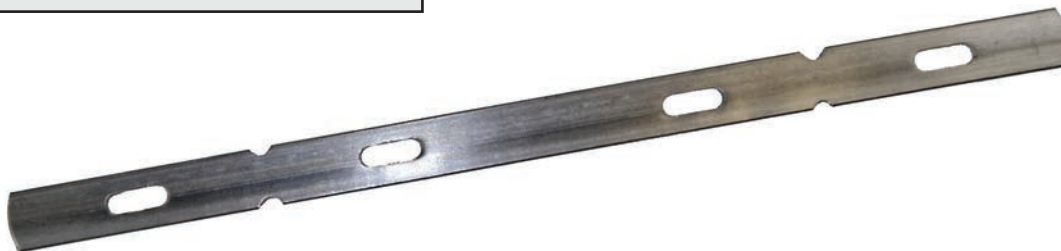



# Inserts

We manufacture many different types of inserts from basic straight loops to thin slab inserts with a ferrule or coil in sizes ranging from 1/2" to 1" and varying lengths, with more sizes and types of inserts to come.



Coil Bolt Dia.	Height	Length	D Wire Dia.	Min. Edge Distance	Min. Corner	Tension (lbs.)	Shear (lbs.)
1/2"	1-3/4"	4-11/16"	.256"	6"	6"	1,520	1,090
3/4"	3-1/2"	5-1/4"	.327"	9"	9"	3,570	2,600
1"	2-5/16"	5-11/16"	.327"	8"	8"	2,460	1,970
1"	4-1/2"	5-11/16"	.327"	12"	12"	5,280	4,000

Thin Slab  
Insert Specs

Bolt Diameter UNC Thread	Length	A	B	Wire Dia	Min Edge	Min Corner	Tension (lbs)	Shear* (lbs)
				D	Distance			
3/8-16	2-3/4"	1-1/4"	1/2"	.256"	10"	15"	2000	2000
1/2-13	2-3/4"	1-3/8"	9/16"	.256"	7"	10"	2000	2000
5/8-11	3-1/2"	1-5/8"	1-3/16"	.256"	8"	8"	2000	2000
3/4-10	3-1/2"	1-5/8"	1-3/16"	.327"	8"	8"	2000	2000
7/8-9	6"	1-5/8"	1-5/16"	.375"	10"	15"	5300	5300
1-8	6"	1-5/8"	1-5/16"	.375"	10"	15"	5300	5300

Ferrule Loop  
Insert Specs

Diameter	Length	Safe Working Load lbs
1/2"	3"	2,250
	4"	2,250
	6"	3,750
3/4"	4"	2,250
	6"	3,750
	9"	3,750
1"	6"	3,750
	8"	3,750

Straight Coil Loop  
Insert Specs





# Coil Rod

Coil Rod is manufactured with continuous thread from high strength cold rolled steel. Coil Rod is self cleaning and ideal for dirty job sites or for use in concrete formwork and shuttering applications.

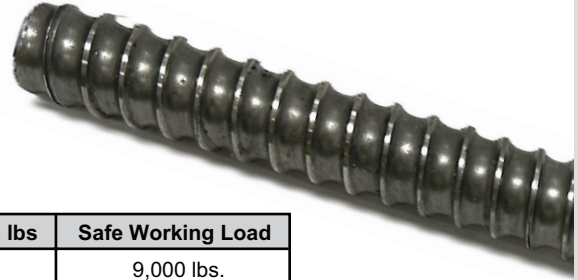

OCM Part No.	D size	L length	Weight per pcs lbs	Safe Working Load
50ACTRP144	1/2"	12FT	6.4	9,000 lbs.
75ACTRP144	3/4"	12FT	13.4	18,000 lbs.
87ACTRP144	7/8"	12FT	20.04	31,000 lbs.
100ACTRP144	1"	12FT	24.48	38,000 lbs.
125ACTRP144	1-1/4"	12FT	41.76	56,000 lbs.
150ACTRP144	1-1/2"	12FT	72.12	68,000 lbs.
50ACTRP72	1/2"	6FT	3.2	9,000 lbs.
75ACTRP72	3/4"	6FT	118	18,000 lbs.
100ACTRP72	1"	6FT	13.22	38,000 lbs.
125ACTRP72	1-1/4"	6FT	22.04	56,000 lbs.
50ACTRP144-G	1/2"	12FT	6.4	9,000 lbs.
75ACTRP144-G	3/4"	12FT	13.4	18,000 lbs.
62ACTRP144	5/8"	12FT	8.5	12,000 lbs.

# Screed Chair Bases & Pipe Holders

Adjustable Pipe Holders for 1/2" and 3/4". Screed chair bases are available. along with 3 types of screed chair bases.

Dimensions		Cradle Head Adjustment Length	Slab 1" Pipe		Slab 1-1/2" Pipe		Suggested Work Load
Height	Width		Min. Inches	Max. Inches	Min. Inches	Max Inches	
1"	2-3/4"	1" (3/4" Pipe Only)	2-1/4"	2-3/4"	2-1/4"	2-3/4"	900
1-1/2"	2-3/4"	1-1/2"	3"	3-1/2"	3-1/2"	4"	900
1-1/2"	2-3/4"	2-1/2"	3-3/4"	4-1/2"	4-1/4"	5"	900
2-1/2"	3-1/2"	3"	4-1/2"	6"	5"	6-1/2"	800
3-1/2"	4-1/2"	4"	5-1/2"	8"	6"	8-1/2"	900
4-1/2"	4-1/2"	4"	6-1/2"	9"	7"	9-1/2"	850
5-1/2"	4-1/2"	6"	7-1/2"	12"	8"	12-1/2"	800

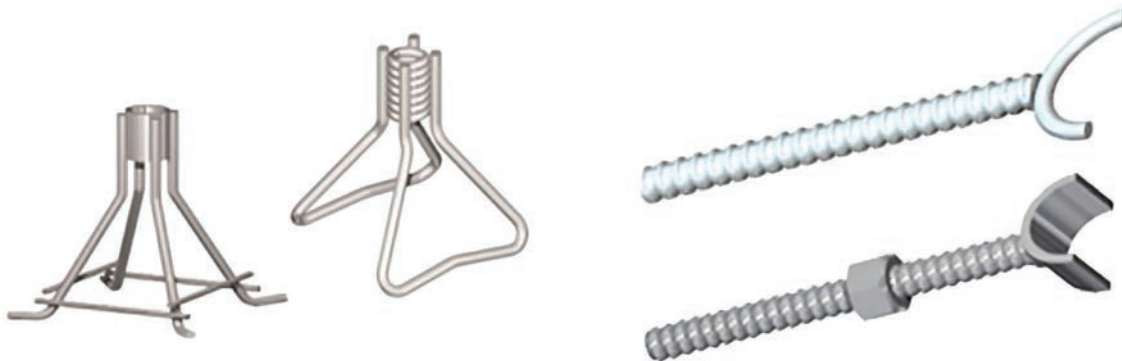



# Slab Bolster Upper

Slab Bolster Upper (SBU) can be ordered in 4 different types, SBU-Plain, galvanized, SBU-Commercial Grade, and SBU-Epoxy Coated, and in sizes ranging from 3/4" to 6" depending on your needs.

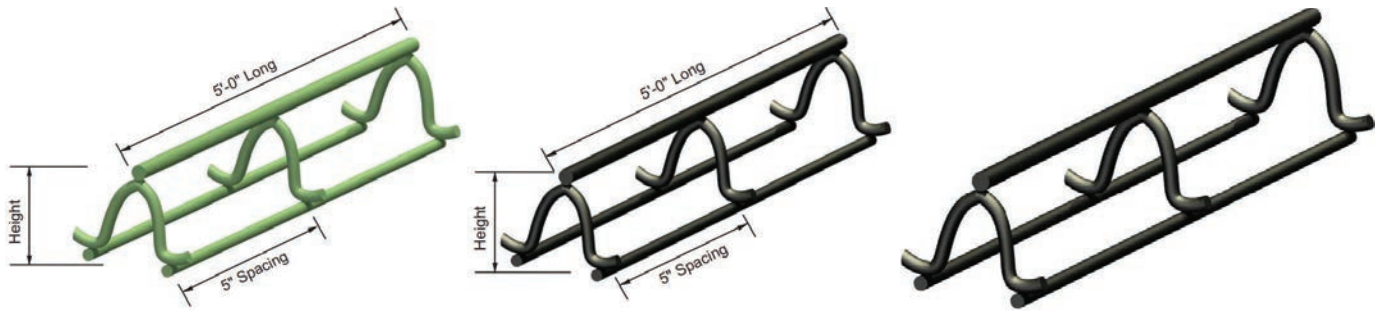

Symbol	Height	Wire Sizes (Gauge)			Geometry
		Carbon Steel			
		Top	Legs	Runner	
SBU	3/4" - 6"	#7 - #4	#9 - #6	#9 - #6	Legs Spaced @ 5" o.c.

OCM Part No.	Height	Length	OCM Part No.	Height	Length
SBU75-P	3/4"	60"	SBU75-E	3/4"	60"
SBU100-P	1"		SBU100-E	1"	
SBU125-P	1-1/4"		SBU125-E	1-1/4"	
SBU150-P	1-1/2"		SBU150-E	1-1/2"	
SBU175-P	1-3/4"		SBU175-E	1-3/4"	
SBU200-P	2"		SBU200-E	2"	
SBU225-P	2-1/4"		SBU225-E	2-1/4"	
SBU250-P	2-1/2"		SBU250-E	2-1/2"	
SBU275-P	2-3/4"		SBU275-E	2-3/4"	
SBU300-P	3"		SBU300-E	3"	
SBU325-P	3-1/4"		SBU325-E	3-1/4"	
SBU350-P	3-1/2"		SBU350-E	3-1/2"	
SBU400-P	4"		SBU400-E	4"	
SBU425-P	4-1/4"		SBU425-E	4-1/4"	
SBU450-P	4-1/2"		SBU450-E	4-1/2"	
SBU475-P	4-3/4"		SBU500-E	5"	
SBU500-P	5"		SBU525-E	5-1/4"	
			SBU550-E	5-1/2"	
			SBU600-E	6"	



## OCM, Inc.

1120 E. Peterson Road, Grayslake, IL 60030  
 Telephone: 866-457-5710 • FAX: 847-462-4259  
 www.ocm-inc.com

## Stocking Locations

**Atlanta**  
 605 Wesleyan Dr. SW  
 Atlanta, GA 30336

**Minneapolis**  
 Suite 300  
 8900 109th Ave N,  
 Champlin, MN 55316

**Dallas**  
 11625 Columbia Ctr.  
 Dallas, TX 75229

**New Jersey**  
 192 Clifford St.  
 Newark, NJ 07105

**Denver**  
 5670 Washington St.  
 Denver, CO 80216

**Philadelphia**  
 250 Hansen Access Rd.  
 King of Prussia, PA 19406

**Ft. Lauderdale**  
 200 S.W. 12th Avenue  
 Pompano Beach, FL 33069

**Portland**  
 1525 SE 10th Ave.  
 Portland, OR 97214

**Houston**  
 Suite 100  
 13323 S. Gessner Rd.  
 Missouri City, TX 77489

**Northern California**  
 2192 W. Winton Ave.  
 Hayward, CA 94545

**Kansas City**  
 3225 Harvester Rd.  
 Kansas City, KS 66115

**Southern California**  
 18320 Mt. Baldy Cir.  
 Fountain Valley, CA 92708





# Slab Bolster

Slab Bolster (SB) comes plain, plastic dipped/tipped, epoxy coated, galvanized, plastic dipped and epoxy coated, or with a plate or “ski” plate. in a variety of different sizes to suit your needs.

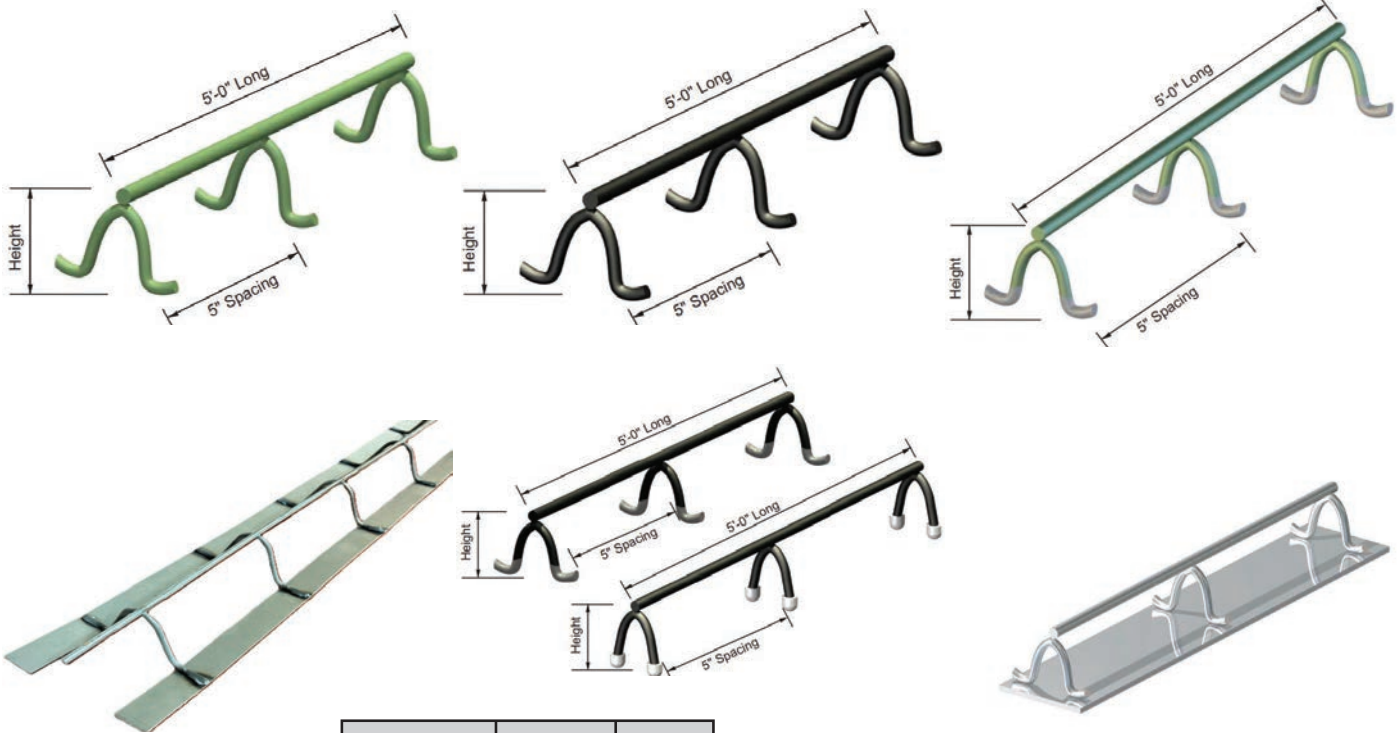

OCM Part No.	Height	Length
SB75-P	3/4"	60"
SB100-P	1"	
SB125-P	1-1/4"	
SB150-P	1-1/2"	
SB200-P	2"	
SB225-P	2-1/4"	
SB250-P	2-1/2"	
SB300-P	3"	

OCM Part No.	Height	Length
SB75-PD2	3/4"	60"
SB100-PD2	1"	
SB125-PD2	1-1/4"	
SB150-PD2	1-1/2"	
SB200-PD2	2"	
SB225-PD2	2-1/4"	
SB250-PD2	2-1/2"	
SB300-PD2	3"	
SB325-PD2	3-1/4"	
SB350-PD2	3-1/2"	
SB400-PD2	4"	
SB75-PT	3/4"	
SB100-PT	1"	
SB150-PT	1-1/2"	
SB200-PT	2"	
SB250-PT	2-1/2"	
SB300-PT	3"	

OCM Part No.	Height	Length
SB75-E	3/4"	60"
SB100-E	1"	
SB125-E	1-1/4"	
SB150-E	1-1/2"	
SB200-E	2"	
SB225-E	2-1/4"	
SB250-E	2-1/2"	
SB300-E	3"	

OCM Part No.	Height	Length
SB100-EPD	1"	60"
SB150-EPD	1-1/2"	
SB200-EPD	2"	
SB300-EPD	3"	

OCM Part No.	Height	Length
SB75-PP	3/4"	60"
SB100-PP	1"	
SB125-PP	1-1/4"	
SB150-PP	1-1/2"	
SB175-PP	1-3/4"	
SB200-PP	2"	
SB225-PP	2-1/4"	
SB250-PP	2-1/2"	
SB275-PP	2-3/4"	
SB300-PP	3"	



# Continuous High Chair Upper

Continuous High Chair Upper (CHCU) is manufactured in sizes ranging from 3' - 9' and can be ordered Plain, Galvanized, or Epoxy Coated.

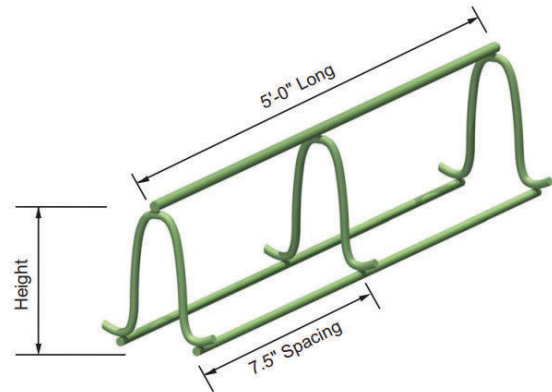
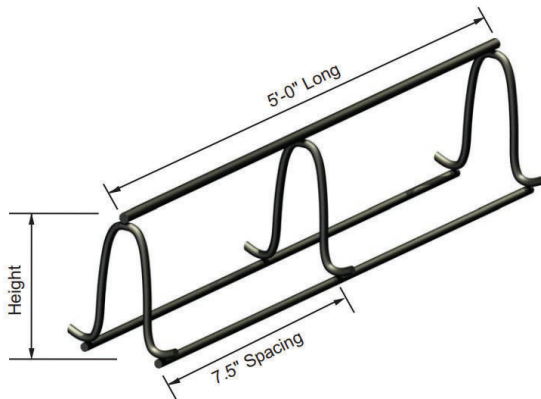

OCM Part No.	Height	Length
CHCU300-P	3"	60"
CHCU350-P	3-1/2"	
CHCU400-P	4"	
CHCU450-P	4-1/2"	
CHCU500-P	5"	
CHCU600-P	6"	
CHCU650-P	6-1/2"	
CHCU700-P	7"	
CHCU800-P	8"	
CHCU850-P	8-1/2"	
CHCU900-P	9"	

OCM Part No	Height	Length
CHCU300-E	3	60"
CHCU350-E	3-1/2"	
CHCU400-E	4"	
CHCU450-E	4-1/2"	
CHCU500-E	5"	
CHCU600-E	6"	
CHCU650-E	6-1/2"	
CHCU700-E	7"	
CHCU800-E	8"	
CHCU850-E	8-1/2"	
CHCU900-E	9"	

## Form Savers

Eliminate the hazards of protruding rebar and costs of form face replacement

Form Savers are manufactured for #4-#9 rebar and come plain or epoxy coated.



Part Number	Bar Size	Thread Type	O.D. x Length
RCOUPLER4	#4 13	1/2" - 13 UNC	3/4" x 1-7/8"
RCOUPLER5	#5 16	5/8" - 11 UNC	7/8" x 2"
RCOUPLER6	#6 19	3/4" - 10 UNC	1-1/16" x 2-3/8"
RCOUPLER7	#7 22	7/8" - 9 UNC	1-1/4" x 2-3/4"
RCOUPLER8	#8 25	1" - 8 UNC	1-3/8" x 3-1/8"

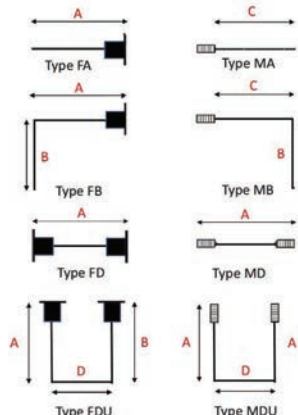

Provide the following information for each Form Saver assembly:

1. Identify the rebar sizes and number of units from project plans.
2. Provide Dimension A for each configuration.
3. Provide Dimension B for each configuration and indicate bend (if any) in degrees.
4. Provide Dimension C for each configuration NC thread is standard.
5. Provide Dimension D for each configuration and indicate bend (if any) in degrees.

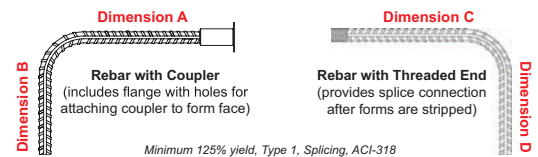

ASTM A-615 Grade 60 Rebar Data						
Rebar Size	Weight (lbs/ft)	Nominal Diameter (in)	Cross Section Area (sq in)	Minimum Load (lbs)		
				Py	1.25 Py	1.50 Pult
#4	0.668	0.500	0.200	12,000	15,000	18,000
#5	1.043	0.625	0.310	18,600	23,250	27,900
#6	1.502	0.750	0.440	26,400	33,000	39,600
#7	2.044	0.875	0.600	36,000	45,000	54,000
#8	2.670	1.000	0.790	47,400	59,250	71,100
#9	3.400	1.128	1.000	60,000	75,000	90,000

ASTM A-615 Grade 60 Coupler Data						
Coupler Size	Thread Size (in / NC)	Coupler Weight (lbs)	Coupler Length (in)	Coupler (in)	Flange (in x in)	Minimum Load Pult (lbs)
#4	1/2"-13NC	0.280	1.750"	.875"	2x2	19,800
#5	5/8"-11NC	0.350	2.000"	1.000"	2x2	30,690
#6	3/4"-10NC	0.480	2.125"	1.125"	2x2	43,560
#7	7/8"-9NC	0.700	2.500"	1.250"	2x2	59,400
#8	1"-8NC	1.200	3.000"	1.500"	2x2	78,210
#9	1-1/8"-7NC	2.000	3.500"	1.750"	3x3	99,000



# Continuous High Chair

Continuous High Chairs (CHC) are available in 60" sections and from 3' -6" in height. You have the choice between plain, dipped or tipped, Galvanized, and epoxy coat finishes.

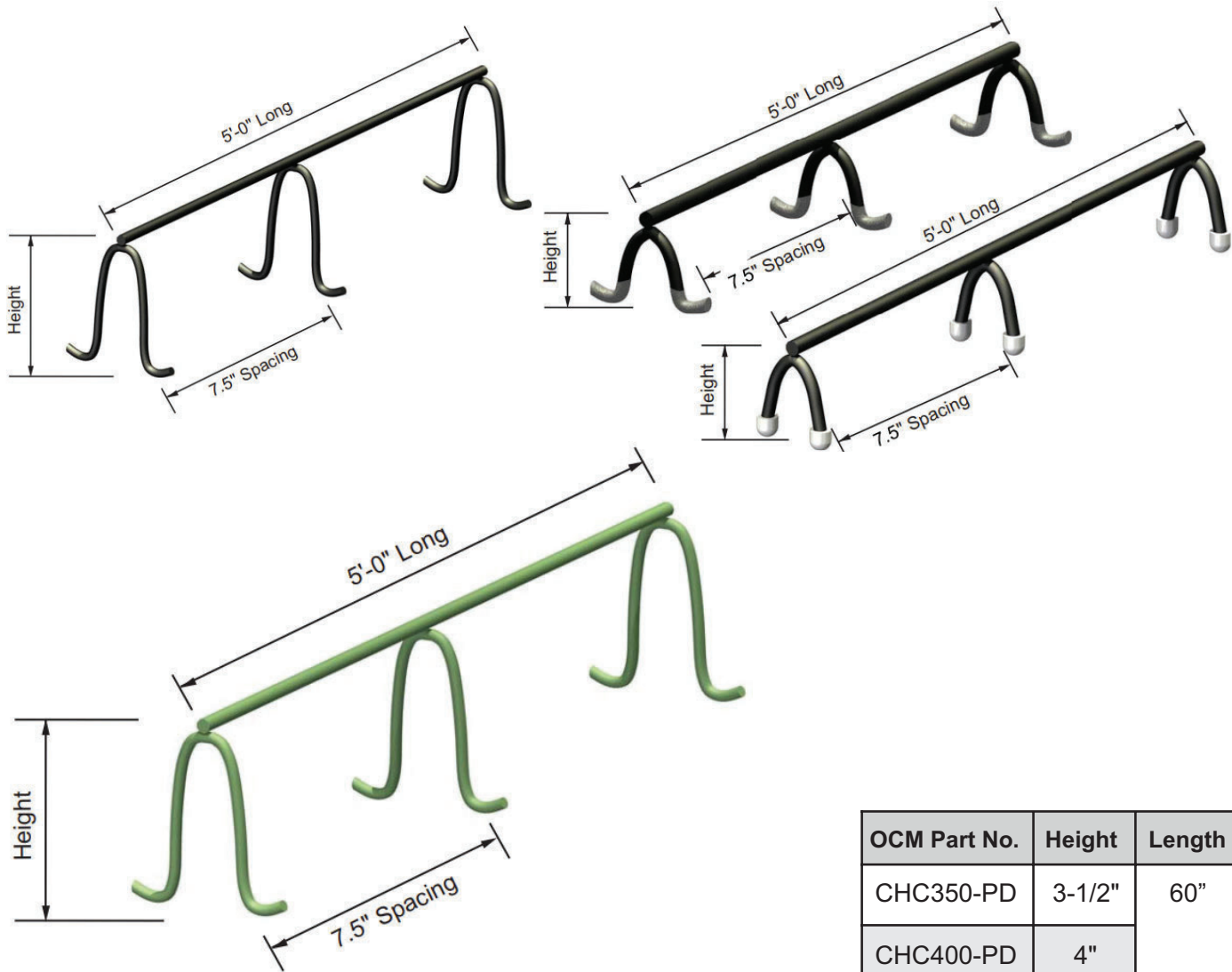

OCM Part No.	Height	Length
CHC300-P	3"	60"
CHC350-P	3-1/2"	
CHC400-P	4"	
CHC500-P	5"	
CHC600-P	6"	

OCM Part No.	Height	Length
CHC350-E	3-1/2"	60"
CHC400-E	4"	
CHC425-E	4-1/4"	
CHC600-E	6"	
CHC800-E	8"	

OCM Part No.	Height	Length
CHC350-PD	3-1/2"	60"
CHC400-PD	4"	
CHC500-PD	5"	
CHC600-PD	6"	
CHC350-PT	3-1/2"	
CHC400-PT	4"	
CHC500-PT	5"	
CHC600-PT	6"	





# Individual High Chairs

Individual high chairs (IHC) come plain, dipped or tipped, epoxy coated, Galvanized, with a sand plate, or with a “ski” plate, sizes range from 2” - 6”.

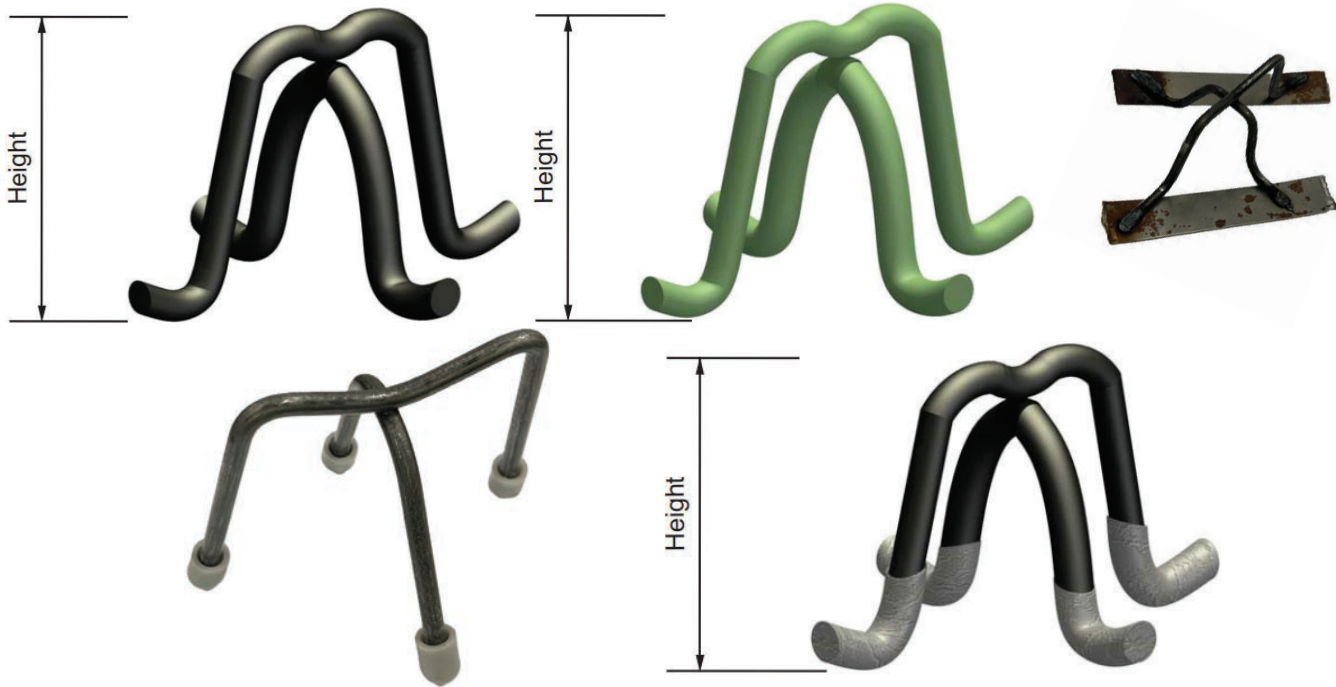

OCM Part No.	Height	Length
IHC200-SP	2"	60"
IHC225-SP	2-1/4"	
IHC250-SP	2-1/2"	
IHC300-SP	3"	
IHC325-SP	3-1/4"	
IHC350-SP	3-1/2"	
IHC400-SP	4"	



OCM Part No.	Height	Length
IHC200-PP	2"	60"
IHC225-PP	2-1/4"	
IHC250-PP	2-1/2"	
IHC300-PP	3"	
IHC325-PP	3-1/4"	
IHC350-PP	3-1/2"	
IHC400-PP	4"	

OCM Part No.	Height	Length
IHC200-P	2"	60"
IHC225-P	2-1/4"	
IHC250-P	2-1/2"	
IHC300-P	3"	
IHC325-P	3-1/4"	
IHC350-P	3-1/2"	
IHC400-P	4"	

OCM Part No.	Height	Length
IHC200-E	2"	60"
IHC225-E	2-1/4"	
IHC250-E	2-1/2"	
IHC300-E	3"	
IHC325-E	3-1/4"	
IHC350-E	3-1/2"	
IHC400-E	4"	

OCM Part No.	Height	Length
IHC200-PD	2"	60"
IHC225-PE	2-1/4"	
IHC250-PD	2-1/2"	
IHC300-PD	3"	
IHC325-PD	3-1/4"	
IHC350-PD	3-1/2"	
IHC400-PD	4"	

OCM Part No.	Height	Length
IHC200-PT	2"	60"
IHC225-PT	2-1/4"	
IHC250-PT	2-1/2"	
IHC300-PT	3"	
IHC325-PT	3-1/4"	
IHC350-PT	3-1/2"	
IHC400-PT	4"	



# Beam Bolster

Beam Bolster (BB) comes plastic dipped, plastic tipped, Galvanized ranging in size from 1" to 5"

OCM Part No.		
Plastic Dipped	Plastic Tipped	Height
BB100-PD	BB100-PT	1"
BB150-PD	BB150-PT	1-1/2"
BB200-PD	BB200-PT	2"
BB250-PD	BB250-PT	2-1/2"
BB300-PD	BB300-PT	3"
BB350-PD	BB350-PT	3-1/2"
BB400-PD	BB400-PT	4"
BB450-PD	BB450-PT	4-1/2"
BB500-PD	BB500-PT	5"
Available in 1/4" sizes.		

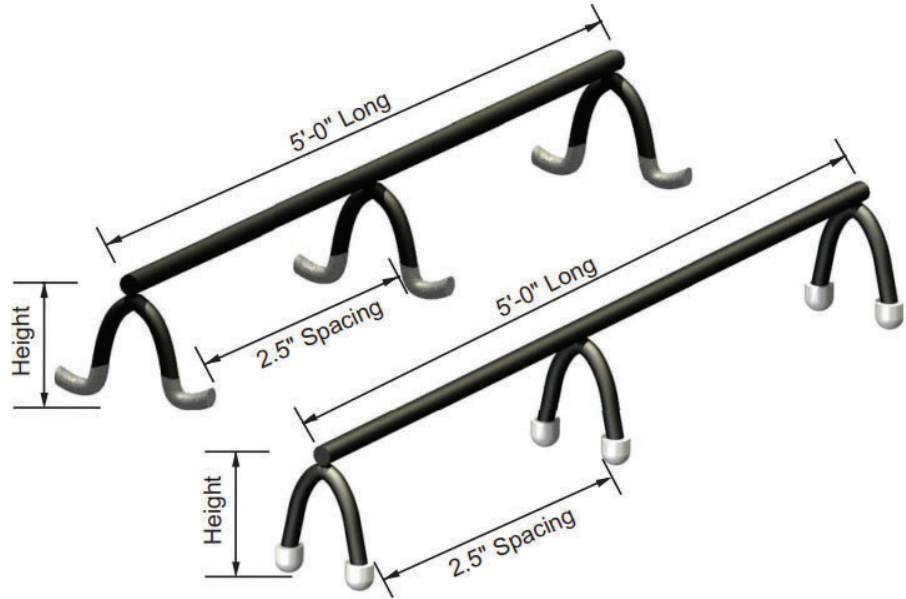

# Beam Bolster Upper

Beam Bolster Upper (BBU) is manufactured in 60 lengths and comes plain, plastic dipped or tipped, Galvanized, and epoxy coated in sizes ranging from 1" to 3"

OCM Part No.	Height	Length
BBU100-P	1"	60"
BBU150-P	1-1/2"	
BBU200-P	2"	
BBU300-P	3"	

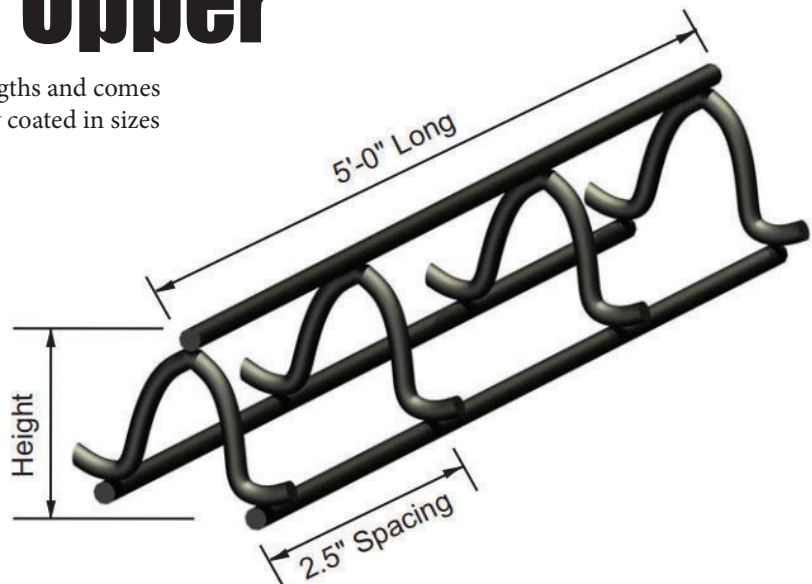



# Steel-Ply Forms

OCM, Inc's Steel Ply Panels and Fillers are made with high quality powder coating that increases durability and weatherability. It also keeps forms looking good for years to come. Our Steel Ply Panels and Fillers comes Standard with upgraded Finn Form solid Birch that provides strength with a smooth surface. The Finn Form is bonded with a phenolic resin adhesive which is water and boil proof. Classic HDO with 100/30 is also available upon request. The Steel Ply Panels and Fillers are compatible with all other industry standard modular handset systems. 9ft and 10ft available upon request.



Sizes	8 FT		6 FT		5 FT		4FT		3 FT	
	OCM Part No.	Weight lbs	OCM Part No.	Weight lbs	OCM Part No.	Weight lbs	OCM Part No.	Weight lbs	OCM Part No.	Weight lbs
24" Panels	SF96X24	75	SF72X24	58	SF60X24	48	SF48X24	40	SF36X24	30
22" Fillers	SF96X22	70	SF72X22	54	SF60X22	46	SF48X22	38	SF36X22	29
20" Fillers	SF96X20	66	SF72X20	50	SF60X20	42	SF48X20	35	SF36X20	27
18" Fillers	SF96X18	63	SF72X18	47	SF60X18	39	SF48X18	32	SF36X18	25
16" Fillers	SF96X16	59	SF72X16	44	SF60X16	37	SF48X16	30	SF36X16	24
14" Fillers	SF96X14	54	SF72X14	40	SF60X14	35	SF48X14	28	SF36X14	22
12" Fillers	SF96X12	50	SF72X12	36	SF60X12	33	SF48X12	26	SF36X12	20
10" Fillers	SF96X10	46	SF72X10	34	SF60X10	30	SF48X10	24	SF36X10	19
8" Fillers	SF96X8	42	SF72X8	32	SF60X8	26	SF48X8	22	SF36X8	17
6" Fillers	SF96X6	39	SF72X6	28	SF60X6	25	SF48X6	19	SF36X6	15
5" Fillers	SF96X5	37	SF72X5	27	SF60X5	23	SF48X5	18	SF36X5	14
4" Fillers	SF96X4	34	SF72X4	25	SF60X4	21	SF48X4	17	SF36X4	13

9 FT and 10 FT available upon request.





# Bridge Hangers

We have a complete line of full and half hangers including weld-on, precast, and hook hangers. All hangers are compatible with industry standard bridge brackets and working parts. Hangers come plain, epoxy coated, and hot dip galvanized.

## Bridge Hanger Families Available Configurations

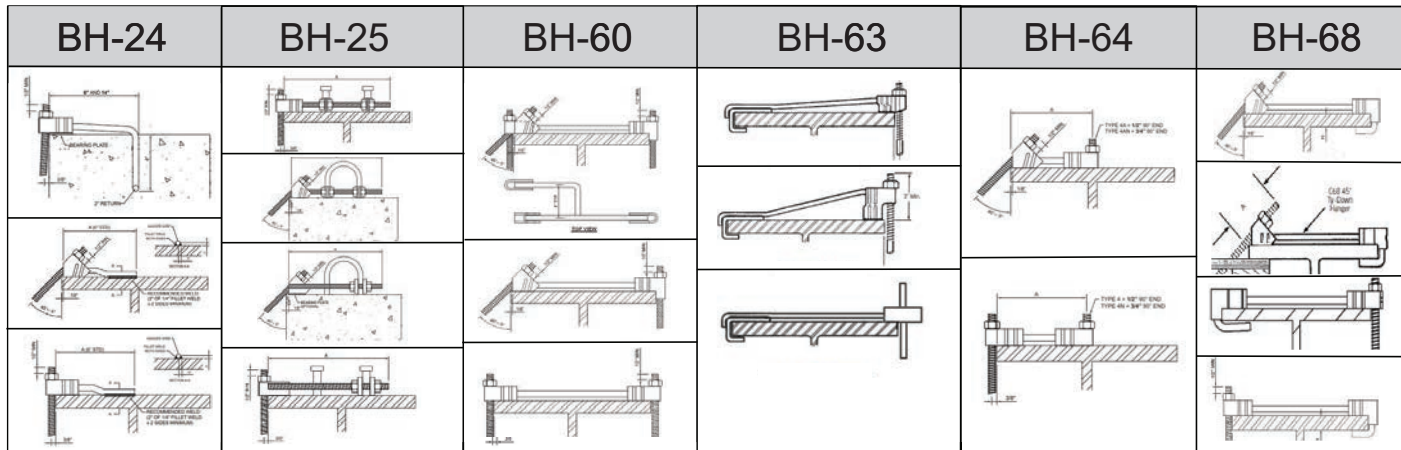

### Available Clips Per Group

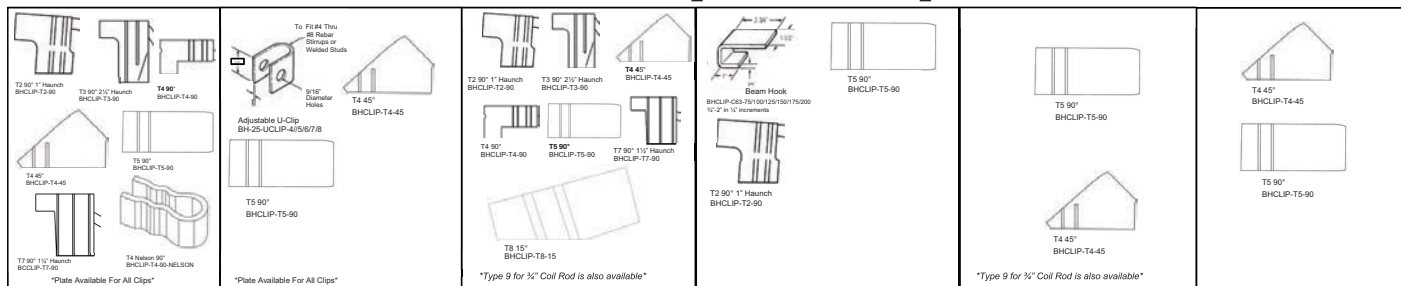

### Long Adjustable Coil Bolts (Deck Bolts)

CM Long Adjustable Coil Bolts are made from high strength steel come with a loose running coil nut installed on the bolt for easy use on the jobsite. OCM Long Adjustable Coil Bolts are commonly used in bridge deck forming applications to attach the overhang bracket to the bridge hanger on the bridge beam.

OCM Part No.	D Size	L Length	AC Across Flats	Weight/pc lbs	Safe Working Load lbs
50A1200CBH0P	1/2"	12"	7/8"	.675	9,000
50A1600CBH0P	1/2"	16"	7/8"	.85	9,000
50A1800CBH0P	1/2"	18"	7/8"	.88	9,000
50A2400CBH0P	1/2"	24"	7/8"	1.19	9,000
50A3000CBH0P	1/2"	30"	7/8"	1.44	9,000
75S1800CBH0P	3/4"	18"	1.25"	2.05	18,000
75S2400CBH0P	3/4"	24"	1.25"	2.63	18,000

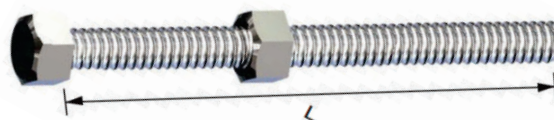



# OCM Locations

- 100 Years of Strength -

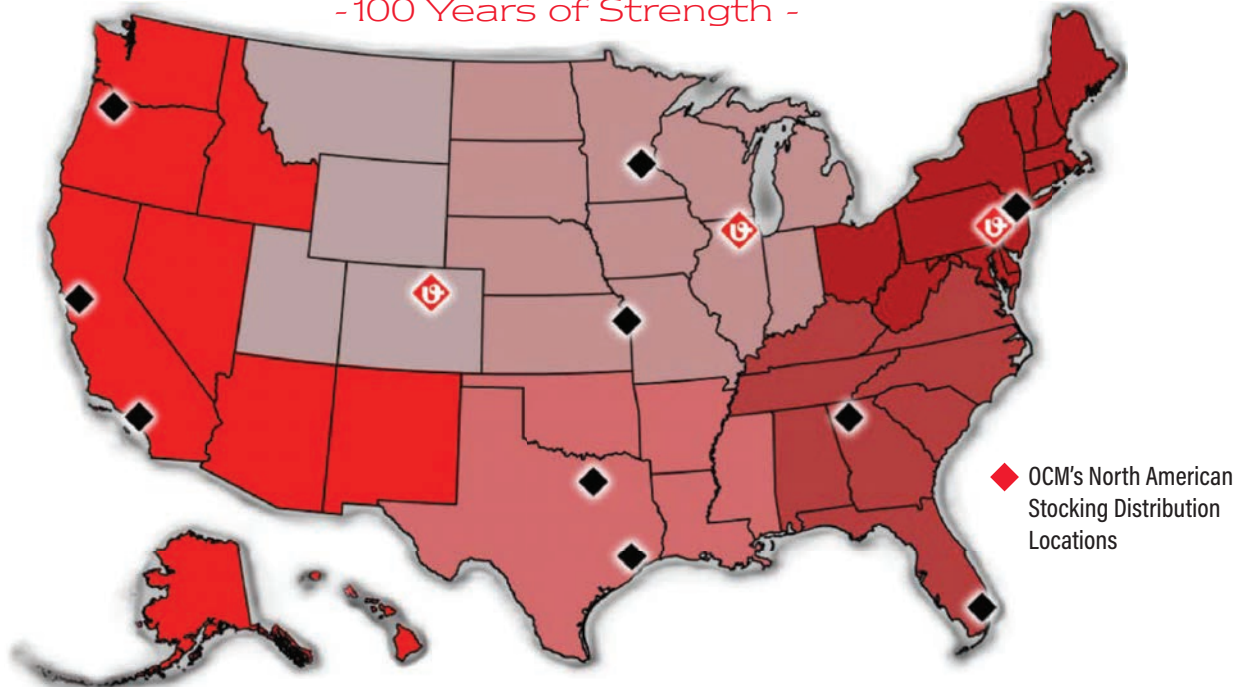

## A GLOBAL LEADER IN METAL WORKING

**OCM, Inc.** is a Subsidiary of OKABE Co., Ltd.. OKABE was founded in 1917 in Japan and has been a full service manufacturer and distributor of concrete construction supplies, and a world leader in the Metal Forming Industry for over one hundred years. Through capital investment and strategic partnerships, Okabe has achieved sales of over half billion dollars and employs over 1,500 people worldwide. OKABEW uses a broad range of metal forming technologies to provide a diverse selection of engineered fasteners and components.

**OCM Inc.** was founded in 2002 as the most direct U.S. subsidiary of Okabe Ltd with a primary focus of developing the forming segment of the construction industry. Early on, OCM was known for our highly respected Adeka Ultra Seal Waterstop line, a prominent brand name to this day. We also established ourselves as an O.E.M. supplier to existing forming manufacturing companies with standard and custom parts. In 2009, we changed course and began to target traditional forming dealers through a growing sales and distribution network of independent manufacturer representatives who stock and sell our product nationally. Over time, we have broadened our product offering and increased inventory levels to support our key dealers regionally and nationally. We have also expanded our target markets to include rebar fabricators and post-tension suppliers with our complete line of metal and plastic bar supports.

To enhance our sales and distribution model, we have continually added more manufacturing for make to order capabilities, domestic requirements like Department of Transportation, and special orders. Our Denver, Colorado facility is a prime example where we manufacture our own handset concrete forms that are superior to other steel frame/plywood face forms in the industry. In 2018, we opened our beautiful new spec building with over 133,000sf of warehouse and office space in Grayslake, IL, just northwest of Chicago. Today, with 13 locations nationwide and growing, we at **OCM** pride ourselves on providing our customers with the BEST COMBINATION of product mix and quality, customer service, sales support, and competitive pricing to help you meet the needs of a very demanding industry! We invite you to contact our customer service department at 1-866-457-5710 or use our CONTACT FORM with your product questions.

### OCM, Inc.

1120 E. Peterson Road, Grayslake, IL 60030  
Telephone: 866-457-5710 · FAX: 847-462-4259  
[www.ocm-inc.com](http://www.ocm-inc.com)

### Stocking Locations

**Northern California**  
2192 W. Winton Ave.  
Hayward, CA 94545

**Atlanta**  
605 Wesleyan Dr. SW  
Atlanta, GA 30336

**Denver**  
5670 Washington St.  
Denver, CO 80216

**Houston**  
Suite 100  
13323 S. Gessner Rd.  
Missouri City, TX 77489

**Minneapolis**  
Suite 300  
8900 109th Ave N,  
Champlin, MN 55316

**Philadelphia**  
250 Hansen Access Rd.  
King of Prussia, PA 19406

**Southern California**  
18320 Mt. Baldy Cir.  
Fountain Valley, CA 92708

**Dallas**  
11625 Columbia Ctr.  
Dallas, TX 75229

**Ft. Lauderdale**  
200 S.W. 12th Avenue  
Pompano Beach, FL 33069

**Kansas City**  
3225 Harvester Rd.  
Kansas City, KS 66115

**New Jersey**  
192 Clifford St.  
Newark, NJ 07105

**Portland**  
1525 SE 10th Ave.  
Portland, OR 97214